

ASi-5 – Great data bandwidth, short cycle times

2 x counter inputs, individually configurable and parameterizable as:

- 2 x 2-channel input
- or
- 2 x 1-channel input
- or
- up to 4 x digital inputs



(Figure similar)

A/B inputs

Frequency and period duration measurement with and without filtering

Unused counter inputs can also be used as standard inputs

Impulse counter and Encoder (24 V)

High protection category IP67



Figure	Housing	Inputs digital	Range of values	Counting rate	Input voltage (sensor supply) ⁽¹⁾	ASi connection ⁽²⁾	ASi address ⁽³⁾	Article no.
	IP67, depth: 35 mm	2 x counter inputs	impulse: -2147483647 ... 2147483647 dec.	max. 250 kHz	out of ASi	ASi profile cable	1 ASi-5 address	BWU4996

- (1) **Input voltage (sensor supply):** Inputs are supplied by ASi or by AUX (auxiliary 24 V power). If supplied by ASi, inputs shall not be connected to earth or to external potential.
- (2) **ASi connection:** The connection to ASi as well to AUX (auxiliary 24 V power) is made via yellow resp. black ASi profile cable with piercing technology or via M12 socket (in IP20 via clamps).
- (3) **ASi address:** AB addresses (max. 62 AB addresses/ASi network), 2 AB addresses (max. 31 modules with 2 AB addresses), Single addresses (max. 31 Single addresses/ASi network), ASi-5 address (max. 62 ASi-5 addresses/ASi network), mixed use allowed. Upon request, ASi-3 nodes are available with specific ASi no-de profiles. For modules with two ASi-3 nodes the 2nd ASi-3 node is turned off as long as the 1st ASi-3 node is addressed to address "0".

Article No.		BWU4996
General data		
Device type		counter input
Connection		
ASi connection		profile cable and piercing technology
Periphery connection		2 x M12 cable socket, straight, 5 poles
Cable		1 m max. allowed tensile strain 10 N
ASi		
Address		1 ASi-5 address
Required master profile		M5
Since ASi specification		5
ASi process data width		4 byte ⁽¹⁾
Operating voltage		30 V (18 ... 31.6 V)
Max. current consumption		250 mA
Max. current consumption without sensor/ actuator supply		50 mA
Input		
Number		depending on configuration: • 2 x 1-channel • 2 x 2-channel • or up to 4 x digital inputs
Counting rate		max. 250 kHz
Range of value		impulse: -2147483647 ... 2147483647 dec. (start value configurable)
Power supply		out of ASi
Sensor supply		short-circuit and overload protected according to EN 61131-2
Power supply of attached sensors	up to +40 °C	200 mA ⁽²⁾
	at +55 °C	200 mA ⁽²⁾
	at +70 °C	140 mA ⁽²⁾
Display		
LED ASi (green)		on: ASi voltage on flashing: ASi voltage on, but peripheral fault ⁽³⁾ or address 0 off: no ASi voltage
LED FAULT (red)		on: ASi address 0 or ASi node offline flashing: peripheral fault ⁽³⁾ off: ASi node online
LED C1A, C2A (yellow)		1-channel mode on: signal at pulse counter input 1, 2 (Pin4) off: no signal 2-channel mode with 4-times evaluation on: rising/falling edge at channel A of counter input 1, 2 (Pin4) 2-channel mode without 4-times evaluation on: period recognized state of the inputs I1, I3
LED C1B, C2B (yellow)		1-channel mode on: status input 1, 2 (Pin2) active if bit USE CHx = 1 ⁽³⁾ off: status input 1, 2 (Pin2) not active if bit USE CHx = 1 ⁽³⁾ or bit USE CHx = 0 2-channel mode with 4-times evaluation on: rising/falling edge at channel B of counter input 1, 2 (Pin2) 2-channel mode without 4-times evaluation no function state of the inputs I2, I4

Article No.	BWU4996
Environment	
Applied standards	EN 61000-6-2 EN 61000-6-3 EN 61131-2 EN 60529
It can be used with a switched AUX cable, which is passively safe up to SIL3/PLe	yes ⁽⁴⁾
Operating altitude	max. 2000 m
Ambient temperature	-30 °C ... +55 °C (up to max. +70 °C) ^{(2) (5)}
Storage temperature	-25 °C ... +85 °C
Housing	plastic, for screw mounting, suitable for cable ducts (≥35 mm installation depth)
Pollution degree	2
Protection category	IP67
Tolerable loading referring to humidity	acc. EN 61131-2
Max. tolerable shock load	30g, 11 ms, acc. EN 61131-2
Max. tolerable vibration stress	5 ... 8 Hz 50 mm _{pp} /8 ... 500 Hz 6g, acc. EN 61131-2
Insulation voltage	≥ 500 V
Weight	200 g
Dimensions (W / H / D) in mm	60 / 45 / 35

(1) The ASi-5 process data bandwidth depends on the ASi-5 profile. Further selectable profiles can be found in the hardware catalog of the Bihl+Wiedemann Suite or in the configuration manual.

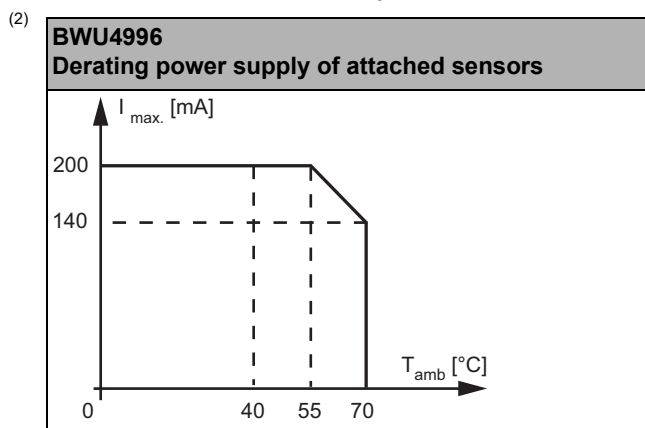

(3) See table "Peripheral fault indication"

(4) The module is suitable for use in passively safe paths as it has no connection to an AUX potential.

(5) Maximum ambient operating temperature +55 °C according UL certificate for the use in the USA and Canada

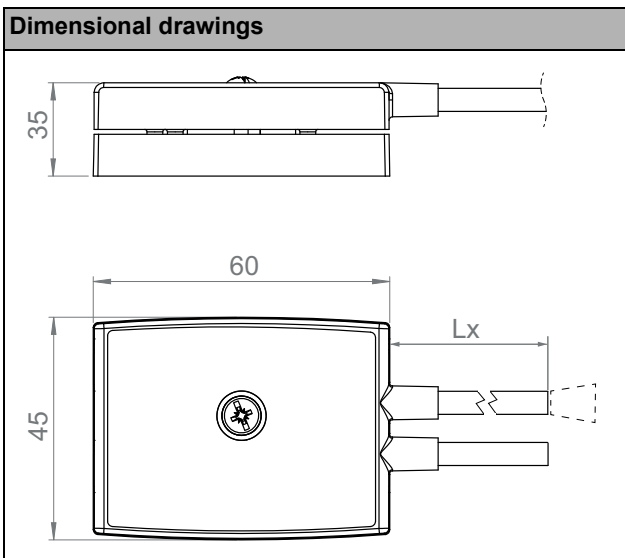

Article no.	Peripheral fault indication		
	counter overflow/underflow and RO Chx = 0	overload sensor supply	status input (Pin2) in 1-channel mode is not active but bit USE CHx = 1
BWU4996	•	•	•

Programming (ASi Bit-setting) standard profile - factory default setting

Article no.	Byte	Bit							
		D7	D6	D5	D4	D3	D2	D1	D0
BWU4996	0	Input							
	1	Channel 1 counter value, low byte							
	2	Channel 1 counter value, high byte							
	3	Channel 2 counter value, low byte							
	3	Channel 2 counter value, high byte							

Article no.	Byte	Bit							
		D7	D6	D5	D4	D3	D2	D1	D0
BWU4996	0	reserved ⁽¹⁾	RO Ch1	USE Ch1	4TE Ch1	2C Ch1	CW Ch1	SV Ch1	RS Ch1
	1	Prescaler Index Ch1 (integer) ⁽²⁾							
	2	reserved ⁽¹⁾	RO Ch2	USE Ch2	4TE Ch2	2C Ch2	CW Ch2	SV Ch2	RS Ch2
	3	Prescaler Index Ch2 (integer) ⁽²⁾							

(1) Reserved bits have to be set to zero, otherwise an timer error could occur.

(2) see table "Prescaler Index"

Name	Explanation
RO Chx	Rollover: 0 = Counter stops at highest/lowest value in case of overflow/underflow 1 = Counter counts with lowest/highest value in case of overflow/underflow
USE Chx	use Pin2 channel x 0 = in 1-channel mode (pulse counter) Pin2 is ignored 1 = in 1-channel mode (pulse counter) Pin2 is used as status input
4TE Chx	4-times evaluation: 0 = no 4-times evaluation 1 = in the 2-channel counting mode (bit 2C CHx =1) rising and falling edges on both channels are counted separately.
2C Chx	counter mode channel x 0 = 1-channel input counter (pulse counter) 1 = 2-channel input counter (encoder)
CW Chx	direction of rotation channel x 1-channel input counter (bit 2C Chx = 0) 0 = counting upwards 1 = counting downwards 2-channel input counter (bit 2C Chx = 1) 0: CxB before CxA = counting upwards 1: CxB before CxA = counting downwards
SV Chx	start value channel x 0 = start value 0 (default = 0) 1 = start value 1 (default = -2147483647)
RS Chx	reset channel x RS changes from 0 to 1: counter starts with start value 0 resp. start value 1 RS changes from 1 to 0: counter stops and keeps last value

Article no.	Prescaler Index											
BWU4996	Index (dec)	255	...	8	7	6	5	4	3	2	1	0
	Prescale value	reserved				128	64	32	16	8	4	2

Pin assignment

Signal name	Explanation
C x channel A, B	counter input x channel A, B (2-channel mode)
Status x	status input x (1-channel mode)
Pulse x+	pulse counter input x, high rise (1-channel mode)
24V _{out} of ASi	power supply, out of ASi, positive pole (sensor supply)
0V _{out} of ASi	power supply, out of ASi, negative pole (sensor supply)
Shield	shield

Connections							
Article no.	M12 connection	Marking	Pin1	Pin2	Pin3	Pin4	Pin5
BWU4996	Configuration as: 2 x 2-channel input						
	X1	C1A/C1B	24 V _{out} of ASi	C1 Channel B	0 V _{out} of ASi	C1 Channel A	n.c.
	X2	C2A/C2B	24 V _{out} of ASi	C2 Channel B	0 V _{out} of ASi	C2 Channel A	n.c.
	Configuration as: 2 x 1-channel input						
	X1	C1A/C1B	24 V _{out} of ASi	Status 1	0 V _{out} of ASi	Pulse 1 +	n.c.
	X2	C2A/C2B	24 V _{out} of ASi	Status 2	0 V _{out} of ASi	Pulse 2 +	n.c.
	Configuration as: up to 4 x digital inputs						
	X1	C1A/C1B	24 V _{out} of ASi	I2	0 V _{out} of ASi	I1	n.c.
	X2	C2A/C2B	24 V _{out} of ASi	I4	0 V _{out} of ASi	I3	n.c.

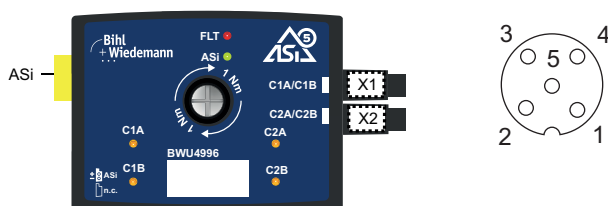

Line termination with sealing profiles



max. IP54

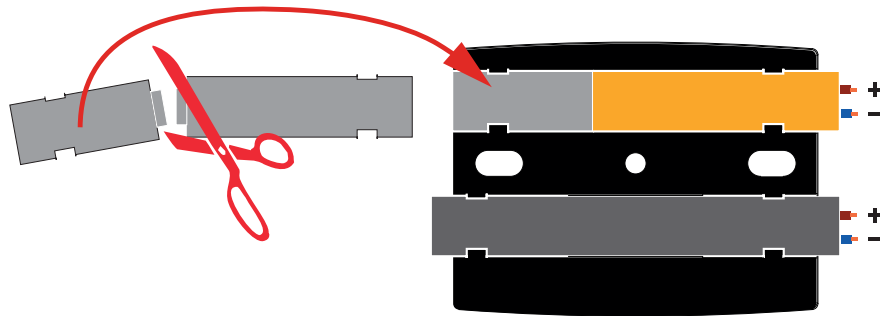

Accessories:

- Sealing profile IP67 (IDC plug), 60 mm (art. no. BW3282)
- ASi-5/ASi-3 Address Programming Device (art. no. BW4925)